

ZW-6 series

HITACHI

Reliable solutions

# ZW310

Tier 4 Final  
Certified

**311 hp** 232 kW  
Engine Output, Max, Gross  
(ISO 14396)

**302 hp** 225 kW  
Engine Output, Max, Net  
(ISO 9249)

**5.5 yd<sup>3</sup>** 4.2 m<sup>3</sup>  
Bucket capacity

**53,310 lbs** 24,180 kg  
Operating weight





# ZW310-6 NO COMPROMISE

The ZW310-6 incorporates unique Hitachi technology that has been specially developed for the ZW-6 medium wheel loader range. It offers exceptional levels of performance without compromising on efficiency, thanks to low levels of fuel consumption.

The new model typifies Hitachi's unwavering focus on manufacturing high-quality, reliable and durable products. The ZW310-6 is also extremely versatile for a variety of industry solutions.



**6. COMPLETE RELIABILITY**



**8. BUILT FOR DURABILITY**



**10. OUTSTANDING VERSATILITY**





12. THE HIGHEST QUALITY



14. DRIVEN BY TECHNOLOGY



# DEMAND PERFECTION

Designed and built in Japan using pioneering technology, the ZW310-6 delivers exceptional productivity at the lowest possible cost of ownership. Hitachi has developed the medium wheel loader to perfection, with a focus on enhanced environmental awareness, operator comfort and safety.



## **Powerful performance**

Quick power switch increases engine output when required.



## **Industry-leading safety**

360° visibility from the cab.



## **Easy loading operation**

25% improved traction force for easier loading.



## **Easy to operate**

Multifunctional monitor shows information at a glance.



## **Smooth operation**

Ride control minimizes machine pitching.





**Enhanced design**

Excellent rear view thanks to the curved engine hood.



**Low emissions**

SCR system without DPF reduces NO<sub>x</sub> from exhaust gas.



**Environmentally friendly**

More than 90% of parts are recyclable.



**Improved fuel efficiency**

Lock-up transmission and Tier 4 Final-compliant engine.



**Superior comfort**

Spacious cab with several storage compartments.



**User-friendly**

Effortless control with the optional E-stick Steering System.



**Convenient access**

Easy-to-open wide engine covers.

# COMPLETE RELIABILITY

Renowned worldwide for manufacturing robust construction machinery, Hitachi has developed its latest range of wheel loaders to deliver a reliable performance with minimal downtime. This means the ZW310-6 is easy to maintain and operates at the highest levels of efficiency on a wide range of job sites.

## Quick access

The engine covers open fully for the convenience of technical support. The urea tank is also located for safe and easy access from ground level. These help to ensure routine maintenance is completed quickly to ensure a reliable performance.

## Improved fuel efficiency

The lock-up transmission has improved the fuel efficiency of the ZW310-6, which reduces running costs.

## Easy maintenance

For safer and easier maintenance, the battery disconnect switch is standard. This helps to avoid electrical accidents

and retain battery energy during long-term storage.

## Reduced costs

The new Tier 4 Final certified engine does not require a diesel particulate filter, which further reduces fuel consumption and maintenance costs.

## Reliable performance

The lift arm contributes to the reliable performance of the ZW310-6. Its speed has been improved and it lowers smoothly for increased productivity. It is easy to control using the auto leveller and anti-drift system.



Easy access to the engine compartment.





The battery is easy to maintain.



New engine reduces fuel consumption.





ZL310

HITACHI



New rear grill protects radiator compartment.



Durable radiators are corrosion resistant.





**i** Hitachi wheel loaders are tested extensively in job site conditions around the world, in extreme temperatures.



# BUILT FOR DURABILITY

The ZW310-6 lives up to Hitachi's market-leading reputation for manufacturing the toughest construction machinery. It has been designed and engineered to withstand challenging working conditions thanks to a variety of features that enhance its durability.



The optional belly guard provides added protection.

### Increased protection

The newly designed rear grill prevents raw material from the job site entering the radiator compartment. This provides greater protection for this durable component.

### Durable materials

High-quality radiators improve resistance to corrosion and enhance the overall durability of the ZW310-6 wheel loader.

### Additional reinforcement

The optional belly guard protects the machine powertrain and driveshaft from potential damage caused by materials on the ground.

### Efficient cooling

The reversible cooling fan, activated manually or automatically every 30 minutes, ensures that the radiator stays clean during operation.



# OUTSTANDING VERSATILITY

Smooth, quick and precise, Hitachi wheel loaders are valuable assets for a variety of applications. They have been designed with numerous features to increase efficiency and enhance safety on a wide range of job sites, which underlines their versatility.

## **Enhanced rear visibility**

The muffler and air intake have been moved further away from the cab to improve visibility through the rear window.

## **Greater traction force**

The traction force has improved by 25% compared to the previous model. The result is a more efficient loading operation.

## **Efficient flexibility**

The quick power switch increases engine output when more power is instantly required, or when driving uphill.

## **Effective control**

To ensure a smooth drive on all kinds of terrain, the ride control feature prevents unnecessary pitching via the movement of lift arm cylinders.

## **High productivity**

The simultaneous movement of the bucket and lift arm ensures a smooth digging operation. The bucket is prioritized after unloading so that the wheel loader quickly returns to digging, which helps to increase productivity.



Rear visibility has been enhanced by design modifications.





The ride control feature ensures a smooth performance.



The quick power switch increases power when required.





Urea is injected into the exhaust gas to reduce emissions.



Flow control system ensures smooth movement of the lift arm.



**i** The final pre-delivery inspection procedure for each Hitachi wheel loader is typical of Hitachi's dedication to manufacturing products of unfailing quality in response to customer needs.



# THE HIGHEST QUALITY

Using superior design elements, high-quality components and rigorous testing, Hitachi ensures that its wheel loaders are able to set new industry standards. As a result of this approach, the ZW310-6 is one of the quietest wheel loaders and offers the best all around visibility in its class.

## Reduced emissions

Hitachi has developed a selective catalytic reduction (SCR) system that injects urea into exhaust gas to reduce nitrous oxide from emissions. This cutting-edge technology not only helps the environment, but also complies with Tier 4 Final emission regulations.

## Improved comfort

The flow control system ensures the smooth movement of the lift arm when lowering. This means less pitching and a more comfortable experience for the operator.

## Excellent visibility

The 360° panoramic view of the spacious cab creates a comfortable working environment, and helps to increase safety

and productivity. The rear-view camera, in combination with the unique two-piece counterweight, also contributes to excellent all around visibility and safety on the job site.

## Low-noise performance

To significantly reduce noise levels in the cab, sound insulation has been improved. As a result of this and the low-noise engine, operators can enjoy a quieter working environment.

## User-friendly operation

The optional Joystick Steering System enables operators to reach high levels of productivity with effortless steering, and incorporates a number of useful functions.



The optional Joystick Steering System provides exceptional control.



# DRIVEN BY TECHNOLOGY

Advanced technology is a vital element of the design of the new Hitachi wheel loaders. Continuously developing software, components and innovative features, Hitachi is focused on enhancing customers' experiences of using its construction equipment, and constantly exceeding industry expectations.

## **Reduced maintenance**

A new Tier 4 Final certified engine contains a high-volume cooled exhaust gas recirculation (EGR) system, a common rail-type fuel injection system and a diesel oxidation catalyst (DOC) without DPF. This helps to reduce fuel costs and maintenance requirements.

## **Fewer emissions**

The after-treatment device consists of a diesel oxidation catalyst (DOC), urea mixing pipe, SCR system and silencer. This advanced technology is designed to reduce emissions as well as noise levels.

## **Optimum performance**

Hitachi ZW-6 wheel loaders are fitted with a multifunctional LCD color monitor that shows useful information at a glance, such as fuel and urea levels, oil temperature and power modes. It ensures an optimum performance and easy maintenance. It also includes the display for the easy-to-use rear-view camera, which enhances visibility for safe operation.

## **Smaller environmental impact**

The standard auto idle shutdown feature helps to prevent fuel waste, as well as reduce noise levels, exhaust emissions and NOx levels of the ZW310-6 wheel loader.

## **Remote monitoring**

Global e-Service allows ZW310-6 owners to monitor their Hitachi machines remotely via Owner's Site (24/7 online access) and ConSite (an automatic monthly report). These help to maximize efficiency, minimize downtime and improve overall performance.





The LCD monitor shows the machine's status and settings.



The urea tank is located for safe and easy access from ground level.



The SCR system reduces emissions and noise levels.



# REDUCING THE TOTAL COST OF OWNERSHIP



**SUPPORT CHAIN**

Hitachi has created the Support Chain after-sales program to ensure optimum efficiency, as well as minimal downtime, reduced running costs and high resale values.

## **Global e-Service**

Hitachi has developed two remote monitoring systems as part of its Global e-Service online application. Owner's Site and ConSite are an integral part of the wheel loader, which sends operational data daily via GMS to [www.globaleservice.com](http://www.globaleservice.com). This allows immediate access to the Owner's Site, and the vital information that is required for support on job sites.

Comparing the ratio of operating and non-operating hours helps to enhance efficiency. Effective management of maintenance programs helps to maximize availability. Running costs can also be managed by

analyzing the fuel consumption. The location and movements of each machine are clearly displayed for essential planning.

An automatic service report — ConSite — sends a monthly email summarizing the information from Global e-Service for each machine. This includes: daily working hours and fuel consumption data; statistics on the operating mode ratio, plus a comparison for fuel consumption/efficiency, and CO<sub>2</sub> emissions.

## **Technical support**

Each Hitachi service technician receives full technical training from Hitachi Construction Machinery Loaders America Inc. (HCMA) in the USA. These sessions provide access to the same technical knowledge available within the Hitachi quality assurance departments and design centers. Technicians combine this global expertise with the local language and culture of the customer to provide the highest level of after-sales support.



Global e-Service



Technical support



Hitachi Parts

## Extended warranty and service contracts

Every new Hitachi ZW-6 model is covered by a full manufacturer's warranty. For extra protection – due to severe working conditions or to minimize equipment repair costs – Hitachi dealers offer a unique extended warranty called HELP (Hitachi Extended Life Program) and comprehensive service contracts. These can help to optimize the performance of each machine, reduce downtime and ensure higher resale values.

## Parts

Hitachi offers a wide range and a high availability of parts provided by HCMA's US parts warehouse.

- Hitachi Genuine Parts: allow machines to work longer, with lower running and maintenance costs.
- Hitachi Select Parts and Genuine Parts: are of proven quality and come with the manufacturer's warranty.

- Performance Parts: to cope with highly demanding conditions, they have been engineered for greater durability, better performance or longer life.
- Genuine Hitachi rebuilt components are available from HCMA's in-house rebuild center and are offered with a standard warranty.

Whatever the choice, the renowned quality of Hitachi construction machinery is assured.







# BUILDING A BETTER FUTURE

Established in 1910, Hitachi, Ltd. was built upon a founding philosophy of making a positive contribution to society through technology. This is still the inspiration behind the Hitachi group's reliable solutions that answer today's challenges and help to create a better world.

Hitachi, Ltd. is now one of the world's largest corporations, with a vast range of innovative products and services. These have been created to challenge convention, improve social infrastructure and contribute to a sustainable society.

Hitachi Construction Machinery Co., Ltd. (HCM) was founded in 1970 as a subsidiary of Hitachi, Ltd. and has become one of the world's largest construction equipment suppliers.

Incorporating advanced technology, Hitachi construction machinery has a reputation for the highest quality standards. Suitable for a wide range of industries, it is always hard at work around the world – helping to create infrastructure for a safe and comfortable way of living, developing natural resources and supporting disaster relief efforts.

Hitachi ZW wheel loaders are renowned for being reliable, durable and versatile – capable of delivering the highest levels of productivity under the most challenging of conditions. They are designed to provide owners with a reduced total cost of ownership, and operators with the ultimate level of comfort and safety.



# SPECIFICATIONS

Model Name: ZW310-6, EPA Tier 4 Final/EU Stage IV Certified

## ENGINE

Gross power (ISO 14396)	311 HP/1,600 RPM (232 kW/1,600 RPM)
Net power (ISO 9249)	302 HP/1,600 RPM (225 kW/1,600 RPM)
Make/Model	Cummins QSL.9 diesel engine
Type	4-cycle, water-cooled, direct injection with turbocharger and air cooled intercooler
Fuel type	#2 Diesel (Requires ultra-low sulfur fuel.)
Fuel injection pump	Electronically controlled, common rail type
Governor	All speed electrical type
Cooling module type	Hydraulic-driven, suction-type fan, pressurized radiator
Number of cylinders	6
Bore and stroke	4.5" x 5.7" (114mm x 145mm)
Total displacement	543 in <sup>3</sup> (8.9 liters)
Alternator	AC 24V–2.28 kW (95A)
Air cleaner	Dry type (double element)
Starter motor	DC 24V–7.8 kW (10.6 HP)
Battery	12V–108AH (1,000 CCA), 2 units

## TORQUE CONVERTER AND TRANSMISSION

Torque converter	3-element, single-stage, 1-phase				
Transmission	Countershaft type, Full power shift				
	Normal Mode	Power Mode	Normal Mode w/Lock-up clutch	Power Mode w/Lock-up clutch	
Speeds: Forward	1st:	4.1 MPH (6.6 km/hr)	4.3 MPH (6.9 km/hr)	4.1 MPH (6.6 km/hr)	4.3 MPH (6.9 km/hr)
	2nd:	7.0 MPH (11.3 km/hr)	7.3 MPH (11.8 km/hr)	7.0 MPH (11.3 km/hr)	7.3 MPH (11.8 km/hr)
	3rd:	13.8 MPH (22.2 km/hr)	13.8 MPH (22.2 km/hr)	14.0 MPH (22.5 km/hr)	14.0 MPH (22.5 km/hr)
	4th:	22.2 MPH (35.7 km/hr)	22.3 MPH (35.9 km/hr)	22.1 MPH (35.6 km/hr)	22.2 MPH (35.7 km/hr)
Speeds: Reverse	1st:	4.1 MPH (6.6 km/hr)	4.3 MPH (6.9 km/hr)	4.1 MPH (6.6 km/hr)	4.3 MPH (6.9 km/hr)
	2nd:	7.0 MPH (11.3 km/hr)	7.3 MPH (11.8 km/hr)	7.0 MPH (11.3 km/hr)	7.3 MPH (11.8 km/hr)
	3rd:	13.8 MPH (22.2 km/hr)	13.8 MPH (22.2 km/hr)	14.0 MPH (22.5 km/hr)	14.0 MPH (22.5 km/hr)
	4th:	22.2 MPH (35.7 km/hr)	22.3 MPH (35.9 km/hr)	22.1 MPH (35.6 km/hr)	22.2 MPH (35.7 km/hr)

## SYSTEMS REFILL CAPACITY

LOCATION	GALLONS	LITERS
Fuel tank (diesel fuel)	99.1	375
Engine lubricant (including oil pan)	6.3	24
Engine coolant	12.4	47
T/M & T/C	13.5	51
Axle (front/rear)	12.7/12.7	48/48
Hydraulic oil tank	36.2	137
Hydraulic system (including hydraulic tank)	52.8	200
DEF/AdBlue® tank	9.3	35

## HYDRAULIC AND STEERING SYSTEM

Steering type	Articulated frame steering	
Steering mechanism	Hydraulic power steering unit, pilot operated type	
Lift (boom) cylinder	Two (2) double-acting piston type: 5.7" x 34.8" (145mm x 884mm)	
Tilt (bucket) cylinder	One (1) double-acting piston type: 7.1" x 20.7" (180mm x 525mm)	
Steering cylinder	Two (2) double-acting piston type: 3.54" x 17.7" (90mm x 450mm)	
Main oil pump	Variable Piston type: 79.3 GPM/1,000 PSI @ 2,000 RPM (300 LPM/6.9 MPa @ 2,000 RPM)	
Pilot oil pump	Gear type: 22.5 GPM/570 PSI @ 2,200 RPM (85 LPM/X.X MPa @ 2,000 RPM)	
Relief valve set pressure	Loading	4,554 psi, 31.4 MPa (320 kgf/cm <sup>2</sup> )
	Steering	3,974 psi, 27.4 MPa (280 kgf/cm <sup>2</sup> )
HYDRAULIC CYCLE TIME* front end loading, Z bar linkage system		
	Normal Mode	Power Mode
Lifting time (at full load)	5.6 sec.	5.5 sec.
Lowering time (empty)	4.1 sec.	4.1 sec.
Bucket dumping time	1.2 sec.	1.2 sec.
TOTAL	10.9 sec.	10.8 sec.

\* Measured in accordance with SAE J732C

## AXLE SYSTEM

Drive system	4-wheel drive
Front and rear axle	Semi-floating type
Tires	26.5R25 (L-3)
Reduction and differential gear	Two-stage reduction with torque proportioning differential
Final reduction gear	Inboard mounted, internal planetary gear
Oscillation angle	Total 24 (+12°, -12°)

## BRAKE SYSTEM





Service brakes	4-wheel, wet multiple disc brake. Controlled by fully hydraulic system. Dual circuit.
Parking/Emergency brake	Spring-applied, hydraulically-released. Located in transmission.

## Remarks

- Materials and specifications are subject to change without notice and without any obligation on the part of the manufacturer.
- This information, while believed to be completely reliable, is not to be taken as warranty for which we assume legal responsibility.
- Dumping clearance and reach are measured from bucket edge in accordance with SAE J732C.
- Counterweight should not be used with tire ballast.
- This specification sheet may contain attachments and optional equipment not available in your area.

Please contact your local HCMA dealer for additional information.

## BUCKET DATA

			Standard Boom			High Lift Boom
			General Purpose		Material Handling	Material Handling
			Straight Edge With Bolt-on Cutting Edge	Straight Edge With Teeth and Segments	Straight Edge With Bolt-on Cutting Edge	Straight Edge With Bolt-on Cutting Edge
						
Capacity	Heaped	yd <sup>3</sup> (m <sup>3</sup> )	5.5 (4.2)	5.5 (4.2)	6.1 (4.7)	5.5 (4.2)
	Struck	yd <sup>3</sup> (m <sup>3</sup> )	4.8 (3.7)	4.8 (3.7)	5.4 (4.1)	4.8 (3.7)
<b>A</b>	Maximum dumping clearance	ft-in (mm)	10'2" (3,095)	9'8" (2,955)	9'11" (3,010)	11'7" (3,530)
<b>B</b>	Dumping reach (to front of bucket edge or tooth)	ft-in (mm)	4'4" (1,310)	4'8" (1,425)	4'7" (1,400)	4'5" (1,350)
<b>C</b>	Max. hinge pin height	ft-in (mm)	14'6" (4,425)	14'6" (4,425)	14'6" (4,425)	15'11" (4,860)
<b>D</b>	Digging depth (with bucket level)	in (mm)	5" (115)	5" (131)	5" (115)	5" (115)
Breakout force		lb (kN)	44,740 (199)	44,740 (199)	41,815 (186)	44,740 (199)
Bucket tilt-back angle	at ground level	degree	41°	41°	41°	41°
	<b>E</b> at carry position	degree	50°	50°	50°	48°
Overall	<b>F</b> Length	ft-in (mm)	29'7" (9,025)	30'2" (9,205)	30' (9,140)	31'1" (9,470)
	<b>G</b> Height (up to cab top)	ft-in (mm)	11'7" (3,530)	11'7" (3,530)	11'7" (3,530)	11'7" (3,530)
	<b>H</b> Height (bucket fully raised)	ft-in (mm)	20'3" (6,160)	20'3" (6,160)	20'3" (6,160)	21'8" (6,595)
	<b>I</b> Width (outside tire)	ft-in (mm)	9'7" (2,930)	9'7" (2,930)	9'7" (2,930)	9'7" (2,930)
	<b>J</b> Width (outside bucket)	ft-in (mm)	10'2" (3,100)	10'3" (3,120)	10'2" (3,100)	10'2" (3,100)
<b>K</b>	Tread	ft-in (mm)	7'4" (2,230)	7'4" (2,230)	7'4" (2,230)	7'4" (2,230)
<b>L</b>	Wheel base	ft-in (mm)	11'4" (3,450)	11'4" (3,450)	11'4" (3,450)	11'4" (3,450)
Clearance Circle (bucket carry position)	<b>M</b> at outside of bucket	ft-in (mm)	48'2" (14,670)	48'7" (14,800)	48'4" (14,730)	49'4" (15,030)
	at outside of tire	ft-in (mm)	43'5" (13,240)	43'5" (13,240)	43'5" (13,240)	43'5" (13,240)
<b>N</b>	Minimum ground clearance	ft-in (mm)	1'8" (505)	1'8" (505)	1'8" (505)	1'8" (505)
<b>O</b>	Full articulation angle	degree	37°	37°	37°	37°
Operating weight (with ROPS cab)		lb (kg)	53,310 (24,180)	53,420 (24,230)	54,390 (24,670)	53,880 (24,440)
Static tipping load (with ROPS cab)	Straight	lb (kg)	41,490 (18,820)	41,140 (18,660)	39,330 (17,840)	34,480 (15,640)
	Full turn	lb (kg)	36,180 (16,410)	35,870 (16,270)	34,280 (15,550)	30,050 (13,630)

Note: All dimensions, weight and performance data based on ISO 6746-1:1987, ISO 7137:1997, ISO 7546:1983 and ISO 8313:1989

\* Static tipping load and operating weight marked with\* include 20.5R25 (L3) tires (No ballast) with lubricants, full fuel tank and operator.

Machine stability and operating weight depend on counterweight, tire size and other attachments.

## DIMENSIONS

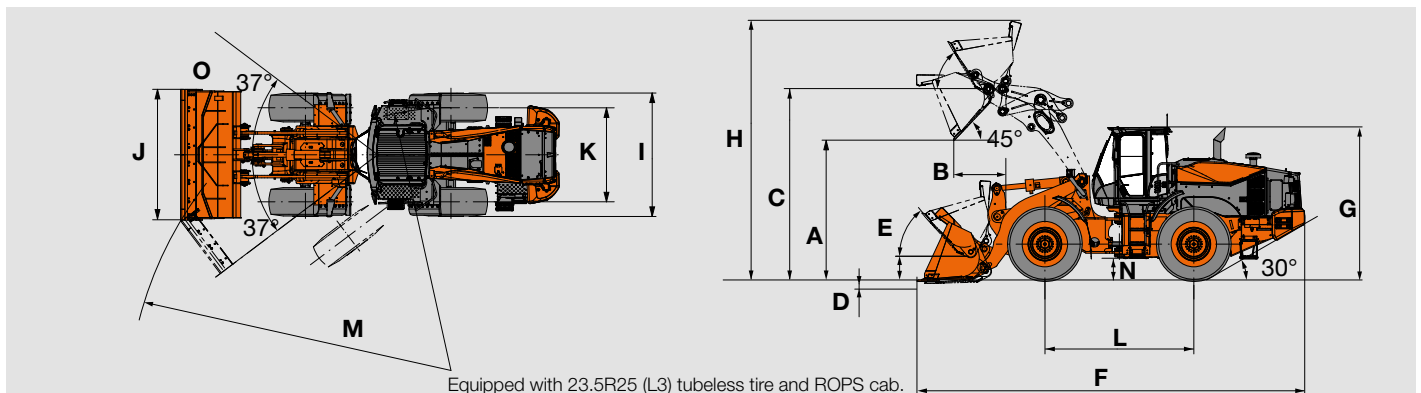



# SPECIFICATIONS

## BUCKET SELECTION CHART

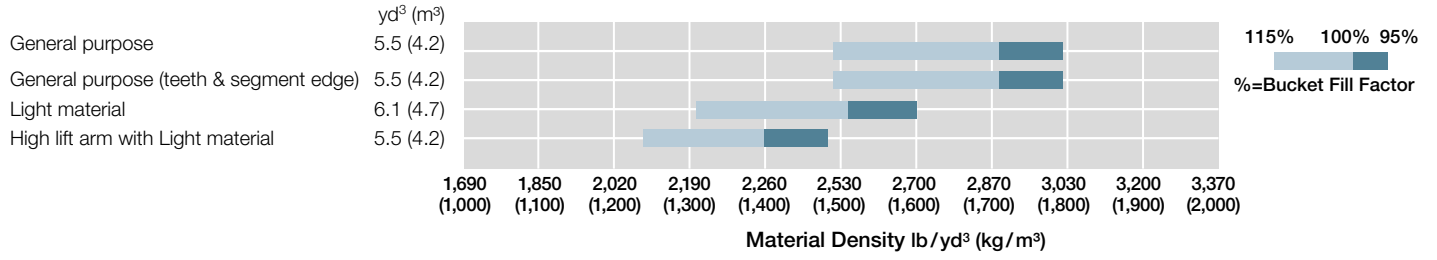

# EQUIPMENT DATA

## STANDARD EQUIPMENT

### ENGINE

Air cleaner, double element
Auto idle shut down
Cold start (intake air heater)
Cooling fan, automatic reversible
Cummins QSL9 diesel engine
EGR System
Engine block heater 120 V
Fuel filter (Main)
Fuel pre-filter, w/water separator
Pre-Cleaner, turbine style
Rain cap
SCR catalyst and DOC
VGT (variable geometry turbocharger)
Work mode selector

### POWERTRAIN

Brakes, service
Enclosed wet disc
Dual system
Inboard mounted
Brake, parking
Spring applied
Oil pressure released
Wet disc type
Differential, torque proportioning type (F/R)
Down-shift switch
Drive shafts, low maintenance
F-R direction selector (2-column mounted/ console mounted)
Lock-up torque converter
Quick Power switch
Transmission, automatic w/load sensing system.
Transmission declutch (3-position L/H/Off)
Transmission mode selection (3-position AUTO1/MAN/ AUTO2)
Universal joints, sealed

### HYDRAULIC SYSTEM

Boom kick-out, dual (operator adjustable in cab)
Bucket positioner (horizontal)
Control lever, dual, pilot-assisted
Control lever lock (electric)
Control valve, 2-function, parallel and tandem control
Pump, variable displacement, load-sensing
Ride control w/load sensing valve and automatic shut-off
Steering, pilot
System; open-center, high-pressure, load-sensing
Valve, anti-drift

### ELECTRICAL

24-volt electrical system
Back-up alarm
Batteries (2), 12 V, 1,000 CCA
Battery disconnect switch
Camera, rear-view
Converter, 12 V/15 Amp
Horn, dual electric
Instrument panel, LCD, color
Lights:
2 Headlights (LED)
2 Forward working lights (LED)
4 Rear working lights (LED)
2 Stop/tail/backup (LED)
Turn signal w/4-way flashers/marker

### CAB

ROPS cab: enclosed cab with sound suppression, front & rear wipers and washers, two rear view and side mirrors, tinted glass, full view latch-back doors, sliding side windows.
Accessory outlet, 12 V
Adjustable armrest/console
Air conditioner/heater/pressurizer
AM/FM/WB radio with AUX input
Ashtray
Cab dome lamps (2)
Cigarette lighter, 24 V
Coat hook
Cup holder (2)
Floormat, sweep-out
Prepped for Loadrite Scale
Retractable seat belt (3-inch)
ROPS/FOPS, ISO 3449 Level II compliant
Seat, deluxe heated w/TLV suspension
Steering column, telescoping and tilting w/quick-release pedal
Steering wheel
Storage box (heated/cooled)
Storage tray
Sun visor

### OTHERS

Articulation locking bar
Counterweight
Drawbar
Fenders, front, w/mudflap
Global e-service, telematic monitoring system
Ladders, inclined
Lifting eyes
Linkage pins, HN bushing
Neutral safety start
Rear grill, hinged
Steps, rear
Vandalism protection
Z-bar loader linkage

### ALARMS, GAUGES, INDICATORS

Alarms (visual & audible)	Aftertreatment device
	Air cleaner element
	Axle oil temperature
	Battery discharge warning
	Brake oil low pressure
	CAN network system
	DEF/AdBlue tank level/quality/system
	Engine oil low pressure
	Engine trouble
	Engine warning
	Fuel filter (water in fuel)
	Hydraulic oil level
	Hydraulic oil temperature
	Main pump oil pressure
	Overheat (engine coolant)
	Transmission oil temp
	Transmission warning
Gauges	DEF/AdBlue tank level
	Engine coolant temperature
	Fuel gauge
	Speedometer
	Tachometer
	Transmission oil temperature
Indicators	Aftertreatment device
	Air conditioner display
	Boom kick-out, dual
	Cold start
	Control lever lock
	Declutch
	ECO-Operating Status
	Fan reverse rotation
	F-N-R Selection
	F-N-R Switch enable
	High beam
	Parking brake
	Shift hold
	Time/Operating hour/ODO
	Transmission mode and status
	Turn signal w/4-way flashers/Marker
	Work light
	Work mode (Normal, Power)

### OPTIONAL EQUIPMENT

Autolube
Belly guard, front chassis, transmission (rear)
Bolt-on cutting edge & segments
Bucket teeth
E-stick steering
High lift boom arm
Hydraulic system, 3rd function
Loadrite scale
Quick coupler & attachments
Satellite GPS Telematics
Single lever hydraulic control w/multifunction grip

Standard and optional equipment may vary by country, so please consult your Hitachi dealer for details.



Hitachi Construction Machinery Co., Ltd. (Hitachi Construction Machinery) was established in 1970, when Hitachi, Ltd. spun off its Construction Machinery Division. Currently, there are 84 companies that comprise the Hitachi Construction Machinery Group providing Reliable solutions for customers in the heavy construction equipment industry. Hitachi Construction Machinery continues to grow as a strong, global, competitive enterprise.

Fast forward to 2010. A joint venture with Hitachi Construction Machinery and Kawasaki Heavy Industries was entered into to further develop the global scope of the wheel loader product line. This relationship combined the huge technological and manufacturing resources of Kawasaki Heavy Industries and Hitachi Construction Machinery Group. This effort has resulted in a very productive, reliable, and cost-effective product.

In 2016 Hitachi Construction Machinery bought 100% of KCM Corporation's stock transitioning to KCMA Corporation. In 2018 Hitachi Construction Machinery took the reins transitioning KCMA Corporation to Hitachi Construction Machinery Loaders America Inc., furthering their commitment to the North American market by introducing the Hitachi brand wheel loader line, offering outstanding parts availability, an unmatched factory component exchange program, customer and dealer training programs, and a wide range of services and programs.

With manufacturing facilities in Banshu, Japan; Ryugasaki, Japan, and Newnan, Ga., Hitachi Construction Machinery Loaders America has the experience and technology to design, engineer, manufacture, and service your next wheel loader. The Hitachi Construction Machinery Loaders America Inc. team is focused on wheel loaders. As a subsidiary of one of the largest construction machinery companies in the world, Hitachi Construction Machinery Loaders America Inc. is securely poised as your go-to source in the North American wheel loader market.



Reliable solutions



## A FULL LINE OF WHEEL LOADERS

- 14 Models
- 25 HP - 512 HP

## REPUTATIONS ARE BUILT ON IT

Prior to operating this machine, including satellite communication system, in a country other than a country of its intended use, it may be necessary to make modifications to it so that it complies with the local regulatory standards (including safety standards) and legal requirements of that particular country. Please do not export or operate this machine outside the country of its intended use until such compliance has been confirmed. Please contact your Hitachi dealer in case of questions about compliance.

These specifications are subject to change without notice. Illustrations and photos show the standard models, and may or may not include optional equipment, accessories, and all standard equipment with some differences in color and features. Before use, read and understand the Operator's Manual for proper operation.

**Hitachi Construction Machinery Loaders America Inc.**  
[www.hitachicm.us](http://www.hitachicm.us)

NA Part #: ZW310-6 BROCHURE  
Global Pub#: KL-EN140NA-US-P